

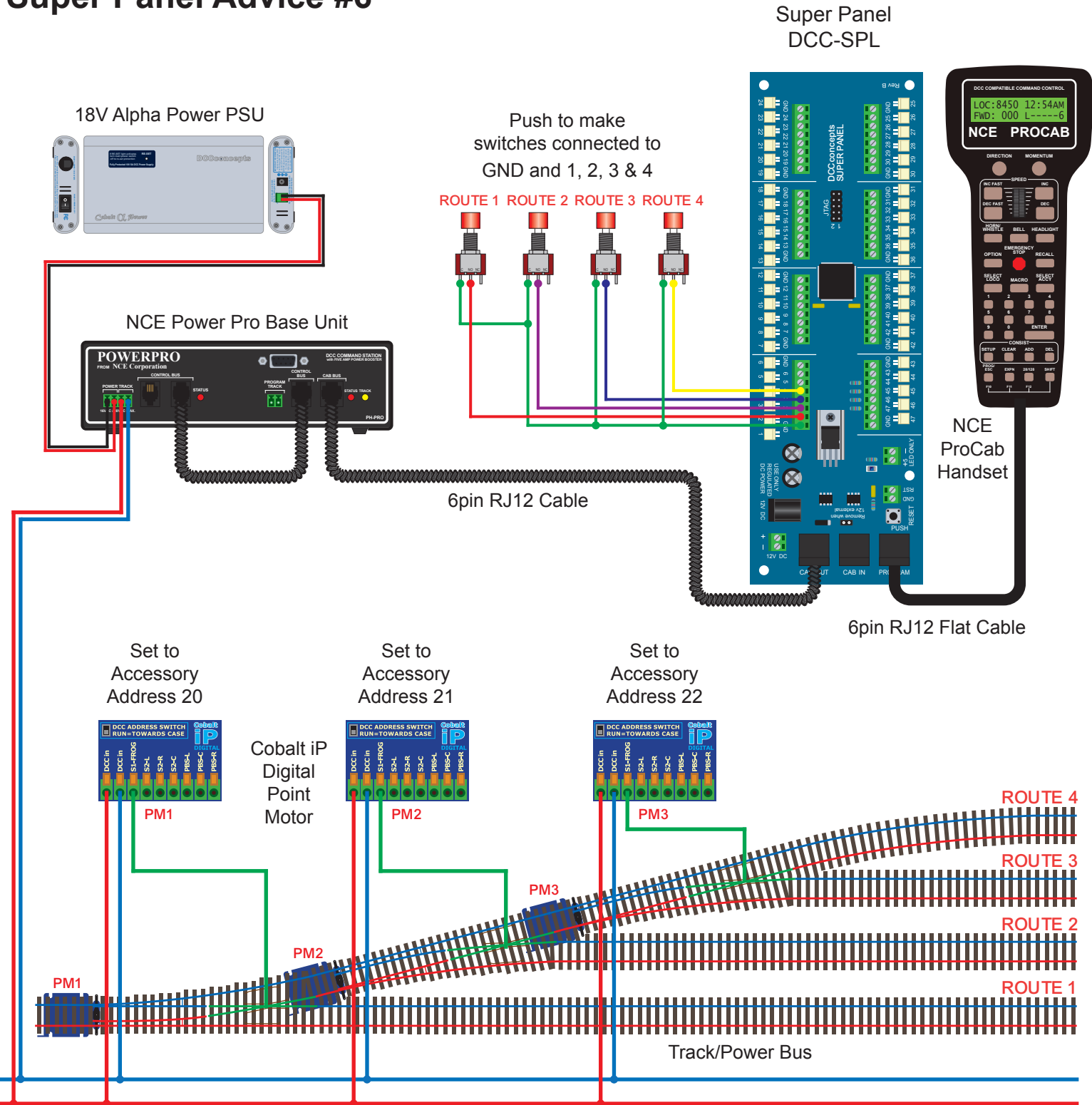

Super Panel Advice #6 - Controlling A Fiddle Yard With Push Buttons

Super Panel Advice #6



Please note - The DCCconcepts Super Panel needs an NCE system to program and operate.