

Intelligent Circuit Breaker iP-CB With Manual Reset Switch & LED

IMPORTANT

Always set the iP-CB trip current with the header to be LOWER than the main system maximum current output.

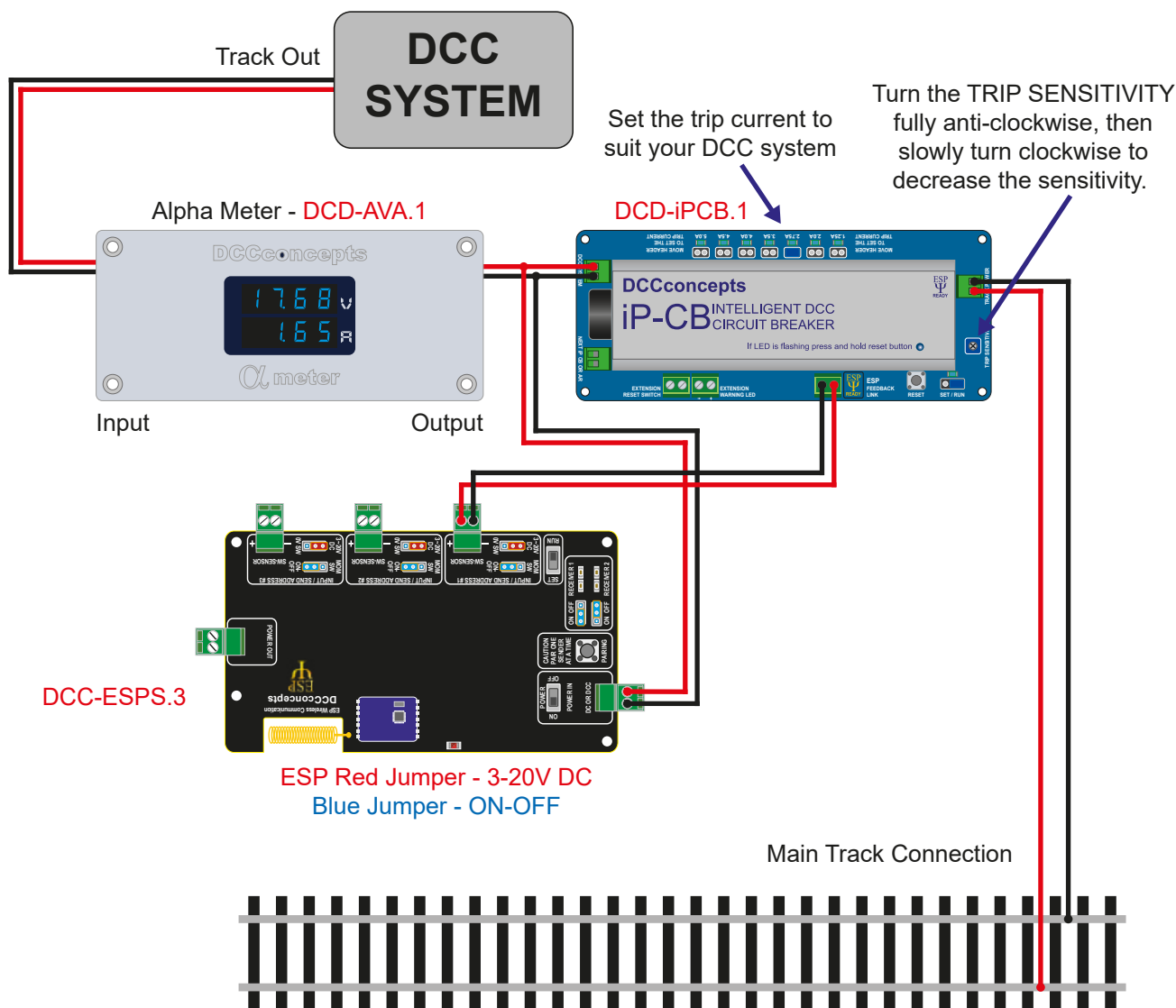

Please Note

Not shown - the ESP Receiver and Alpha Mimic board in the control panel are required to show the warning LED.