



## Wire-Free Operation

DCCconcepts ESP® turns almost any switch, detector or similar device into a simple to address, wireless source. ESP® can trigger actions, give feedback or send DCC control commands without the need for any wires.

No complex set-up or Wi-Fi confusion. Very simple connection. Easy addressing. Easy to understand. Super-easy to use. No limits on connection quantity. No interference with adjacent exhibition layouts. Zero frustration.

### The DCC-ESPS.3 Transmitter

Very easy to use, this unit is the heart of ESP® DCC-ESPS.3 can be powered by a DCC track bus or with any regulated DC power source or battery able to deliver from 12 to 20 volts.

DCC-ESPS.3 has three inputs that can be connected to any form of detection or switch, and three independent wireless outputs, each with its own DCC address.

The ESP® address range is from 1 to 2044.

To complete your wire-free installation, the DCC-ESPS.3 is paired with the DCC-ESPR receiver which receives the commands and delivers them to your DCC system or control panel, either as a direct DCC command or as a "Sniffer" device, so your screen-based DCC system can also receive feedback.

DCC-ESPS.3 can pair with multiple receivers.

Unlike Wi-Fi based systems, ESP® has no limits on the quantity of input channels and there is zero possibility of interference.

ESP® has full power-off memory and is also protected against wrong connections.

**Please read instructions carefully before use.**

**Power OUTPUT only**  
You can use this output to daisy chain the power to your other ESPS.3 units

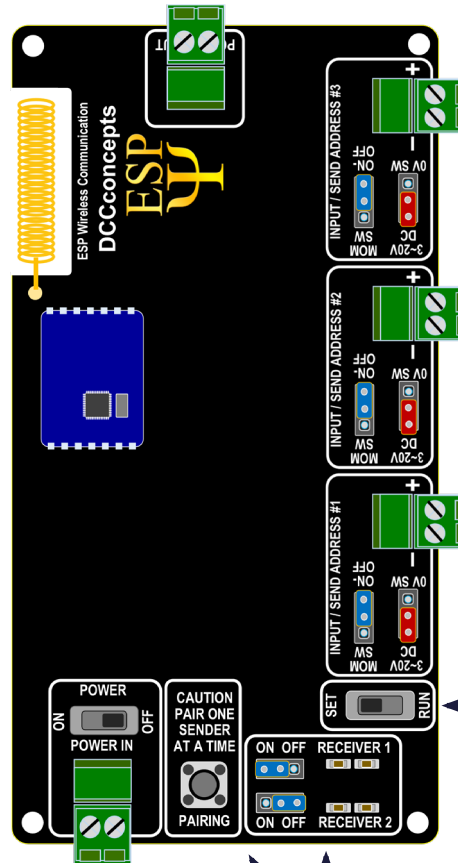

**Power INPUT**  
DCC or DC 12V~23V

### The Pairing Switch & Receiver Pairing Selection Headers

DCC-ESPS.3 can be paired and report to two receivers at the same time if needed.

Move the header for the chosen receiver to ON. Once done, you can turn the power on to both the transmitter and the receiver.

Press the Pairing button on both the sender and the receiver you wish the sender to pair with. The LEDs on both will flash until pairing is completed.

Wire-Free **ESP** Operation

**INPUT #3** Instructions for all inputs  
Confirm the type of switch by moving the **Blue** header to the appropriate position.  
If the switch is unpowered, move the **Red** header to the 0V position. If the switch carries power, move the **Red** header to the 3~20v position.

**INPUT #2**  
If you are using a powered input you must wire with the polarity as shown. (If you do not connect with the correct polarity, the unit will protect itself and not turn on)

**INPUT #1**

### Addressing Switch.

Move to SET. Use your DCC controller as if changing an accessory using your chosen number between 1 & 2044. This will set all 3 outputs in number sequence. (Set #1 to 4 & Addresses will be 4, 5, 6)  
Return the switch to the RUN position.  
Each output will now wirelessly transmit its new address when it is triggered.

### Advice and troubleshooting

- Only make and adjust connections with the power turned off. Be sure to use the correct voltage levels when powering these units.
- Only pair one transmitter at a time and only pair your transmitters to one receiver at a time.
- If your DCC-ESP.3 will not turn on after wiring, check input polarities.
- Remember, addresses 197, 198, 199 are special "Cobalt set-up numbers"

## The DCC-ESPR Receiver

DCC-ESPR is both an ESP® receiver and a 1.5Amp DCC system power bus generator as well as being a very clever “Sniffer” device.

DCC-ESPR receiver is also very easy to use.

DCC-ESPR can be powered by a DCC track bus or with any regulated DC power source or battery able to deliver from 12 to 20 volts.

It has just two pairs of terminals, a power switch and a pairing switch. Connect it to the track bus and it will synchronise mimic panels with all of your accessory operations.

Connect it to the sniffer port of your screen based system and it will update the display.

DCC-ESPR can even be used as the entire basis for an independent DCC power bus, so it really is versatile - and simplicity itself!

DCC-ESPR requires no “programming” and is already provided with a unique address at the time of manufacture. Of course, no two receivers will ever have the same address, so conflicts are 100% impossible!

Unlike Wi-Fi based systems, DCCconcepts ESP® has no limits on the quantity of linked transmitters and there is no need for routers, passwords or computers when using ESP®.

DCC-ESPR has full power-off memory and is also protected against wrong connections.

**Please read instructions carefully before use.**

### DCCconcepts ESP

DCC-ESPS and DCC-ESPR are just the first two of many devices that will soon cover the entire spectrum of DCC control. They will also deliver the DCC promise made many years ago. Less wiring for modellers!

DCCconcepts ESP® is totally independent and can be used with every brand of DCC system in any scale. There is no need at all for other interfaces or “brand adapters”.

Perhaps best of all, ESP® will not mean that you will now need to change everything.

ESP® really IS the future.

ESP® works well with any type or style of switch or detector, so all of the devices that you use right now are already completely ESP® Ready.

**ESP  
Ψ  
READY**

Are YOU ready for ESP®?

# Wire-Free ESP Operation

### DCC Accessory Bus and Sniffer output Terminals

DCC-ESPR's output is pure DCC with an exceptionally accurate, industry-best wave form, guaranteeing the best possible communication in all circumstances.

DCC-ESPR is able to deliver 1.5 Amps directly, enough to power a small DCC accessory bus as well as communicating with and powering even the largest of control panels.

DCC-ESPR is also an effective and reliable “Sniffer” device for direct connection to systems such as ESU, Roco Z21 and others, updating their screens as accessories are triggered.

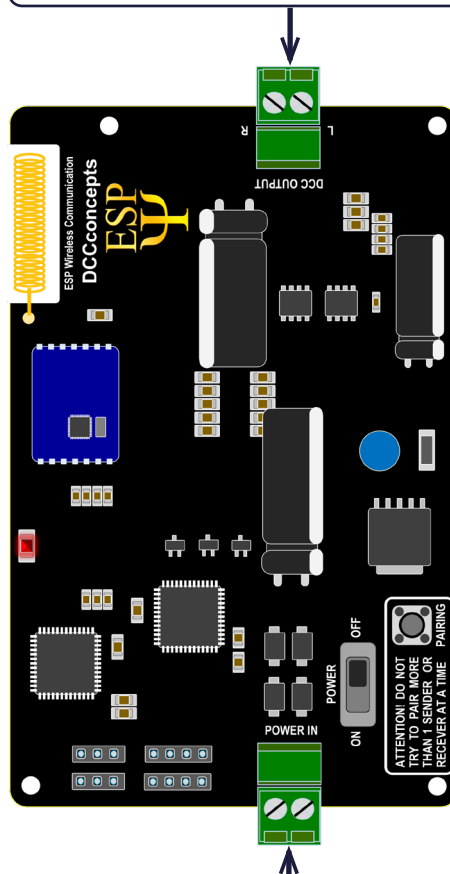

### Power Input & On/Off Switch

Use DCC or DC power, 12V to 23V.  
If you need a power supply, we recommend the DCCconcepts DCP-18.2 (2 Amps, 18V)

### ESP® OPERATING RANGE

In “Layout Size” terms, it is unlimited. We tested up to 200 feet with a building wall between transmitters and receivers with consistent and reliable results.

### Transmitter Pairing Switch

Once paired, the DCC-ESPR receiver will remember very reliably so the only “re-use” needed will be if changing which of your DCC-ESPS units it is paired with.

To pair a transmitter and receiver, first wire both of them and turn the power on.

Press the PAIRING button on both the transmitter and receiver. The onboard LEDs will flash as they find each other, then steady to confirm communication.

You can now pair another ESPS Transmitter.

**When you've finished pairing, press the Pairing Switch again to exit PAIR mode.**

It really is that simple, no matter how many transmitters your layout uses.

### Advice and troubleshooting

- Only make and adjust connections with the power switch turned off.
- Be sure to use the correct voltage levels when powering these units.
- Only try to pair ESP transmitters to one ESP receiver at a time please.

**DCCconcepts: always thinking outside the square**