

ESP Control Of 3 Cobalt iP Digitals & Mimic Board

Control Panel

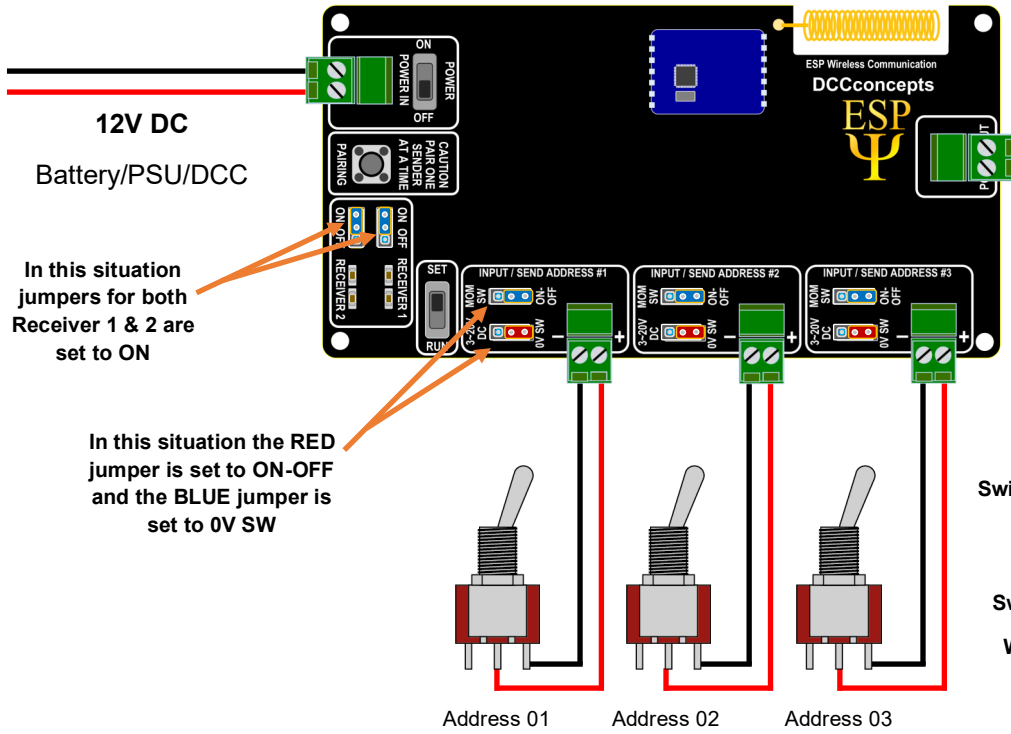

3 CHANNEL TRANSMITTER

DCC-ESPS.3

Switches can be either SPST or SPDT

Switches are paired With RECEIVER 1

Mimic board is paired With RECEIVER 2

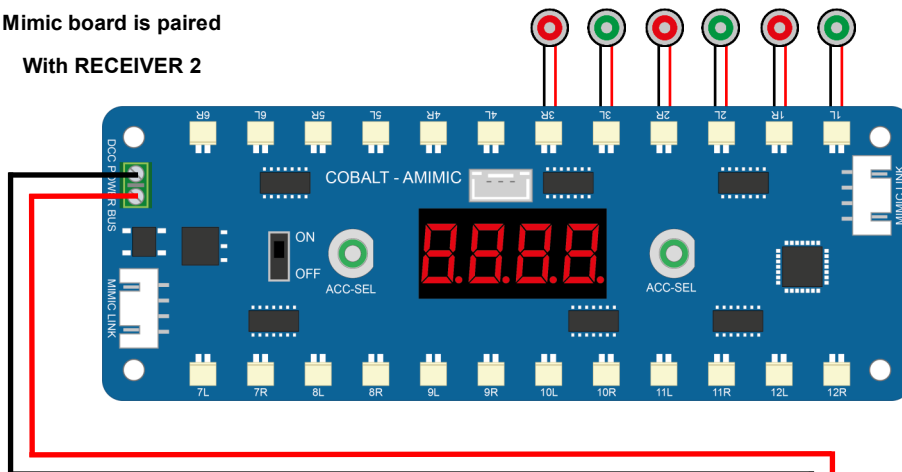

RECEIVER 2

DCC-ESPR.1

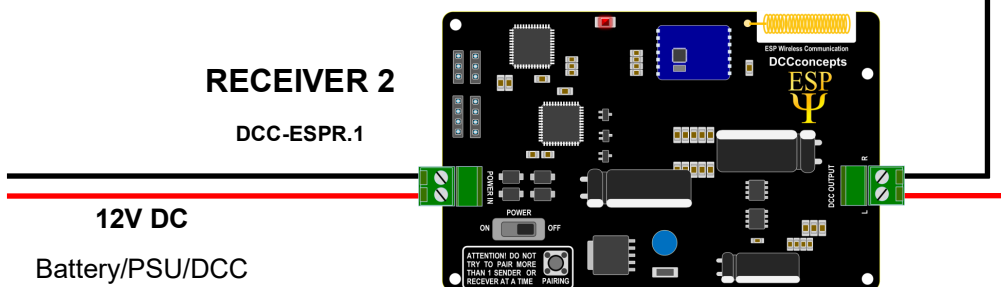



Layout Baseboard

