

Cobalt-SS

OWNERS
MANUAL

Created by
DCCconcepts

MADE
in
CHINA

Cobalt-SS

General Cobalt-SS product information

DCCconcepts Cobalt-SS Surface mount point motor:

Thank you for buying our Cobalt-SS point motors. Cobalt-SS and its control board perform well with DCC or DC power. We cover wiring and control with both power sources later in this manual.

Every single Cobalt-SS is thoroughly tested both during production and prior to packing for sale, so we are confident it will work well.

The final steps for successful use, long life and reliability are of course installation, connection and setting Cobalt-SS up ready for operation.

While installation and connection are not at all difficult, as always there is something new to learn and there are right and wrong ways to do some things - so we would like you to read this manual carefully, work step by step and refer to the manual often during that process.

If you get stuck or have questions at any time, please do not hesitate to call us or email your enquiry to questions@dccconcepts.com.

Each pack of Cobalt-SS will include the following.
(The actual quantity supplied depends on the Cobalt-SS pack size)

- * Comprehensive Instruction booklet.
- * 2, 6 or 12 Cobalt-SS micro-sized Above-Board Point motors
- * 1, 3 or 6 Cobalt-SS control and connection boards
- * 1, 2 or 3 600mm 4-wire Cobalt-SS Extension leads
- * 1, 2 or 3 Adapter PCBs to allow you to economically power TWO or more Cobalt-SS motors from one output. Including Y connection & an adapter with "reverse throw" option for crossovers or passing loops.
- * A generous quantity of tie bar linkage designs suitable for N, OO/HO and O scales, both with and without track-bed.
- * A generous quantity of screws for fixing Cobalt-SS & Control board.
- * **ALL packs also include free samples of our finely tooled scale models of Westinghouse EP point motors.** (We will include 1x OO/HO scale, 1x N scale and 1x O scale sample in all 2, 6 and 12 packs).

The Westinghouse EP prototype point/turnout motor was used widely in many countries including UK, USA, Australia and parts of Europe from the early part of the 20th century. In fact, it is still in use today!

(If you wish to add more of these important details to your layout, they are available in economical 12-packs from your DCCconcepts Dealer)

Warranties and After-Sales Service:

The basic warranty for Cobalt-SS is 12 months from date of purchase. However, we only use the highest quality parts for all of our Cobalt & Cobalt-SS products so should your motor ever fail, please contact us.

Even if your Cobalt-SS fails outside the warranty period we will still do our best to help you. Providing we are satisfied that user error is not the cause or if we cannot clearly identify reasonable cause for failure, we will usually replace any faulty parts free of charge.

We understand that waiting for the return of warranty items can be frustrating for you so we guarantee spare-parts availability, and if we do not have the parts needed for repair available or in stock, we will replace the product rather than inconvenience you.

Please note: Warranties are not transferrable and are offered to the original owner. We do reserve the right to request proof of purchase.

Help and Advice:

These detailed instructions should give you most of the information you will need to install, set up and operate your Cobalt-SS motors. Please read them carefully as most things are explained here.

Additionally, there are additional instructions provided with Cobalt-SS accessories and adapter leads... with both added application manuals and video instructions underway as well. (check our website for updates please)

However we do understand that you may still have some questions, as experience has shown us that there will always be a special application for almost any product we create. Therefore we invite you to email or telephone us if you need more information. Our customer supports staff in Australia and the United Kingdom are ready to help.

Important Information:

Cobalt-SS is very simple to use and connect but please remember that it is a sophisticated 4-wire stepper-motor managed by digital micro-controllers.

All electronics are sensitive to how you handle them and it is very important that you read and follow all of our instructions as you install and connect Cobalt-SS.

Do not remove the plug or try to connect a Cobalt-SS motor directly to AC, DC or DCC.

When adding power to the Cobalt-SS PCB use only a regulated DC power supply 11-23v or a DCC system with an output track voltage between 11 and 23 volts.

NEVER connect active power (eg track power or similar) to the push-button switch inputs of the Cobalt-SS Control PCB. Incorrect wiring or wrong power supply choices will lead to failure which is NOT covered by warranty. Installation & connection must be done with the power off. If in any doubt please ask us first!

Cobalt-SS

Basic Preparation, Planning Installation

Installing your DCCconcepts Cobalt-SS: The Basics.

Please read these instructions first, then keep them close at hand.

Take your time with the first few installations. Work one step at a time and check as you go. Installation is quite simple, all screws and fittings are supplied and the connection between Cobalt-SS and its Control board is a simple plug and socket, so it is easy to do and the whole process will soon become a pleasant and satisfying hobby task.

Preparing your pointwork for Cobalt-SS installation:

These instructions are common to many brands, however as many of our Cobalt-SS customers will use Peco pointwork, we will focus on it here:

* We strongly recommend that you use live frog or "Electrofrog" for all types of pointwork. (We also find that the finer rail of Peco Code 75 is easier to work with and lay well, so please do consider using it)

* Remove the Peco "Snap Spring" before laying the turnout. It is no longer needed. It will increase loading and interfere with smooth changing

* While it is NOT always necessary, we DO suggest that you consider modifying the turnout to properly isolate the frog from the closure rails.

This simple modification will really enhance the reliability of electrical contact in your pointwork. It really IS a simple task & detailed "How to" advice can be found later in this manual OR in the advice section of our website at www.dccconcepts.com. (search "Wiring pointwork" please)

* Cobalt-SS linkages are designed to link to your pointwork via a small hole in the end of the tie-bar (The part that moves the blades). This is VERY easy with Peco. Simply use a sharp blade to cut off the small, hollow vertical pin at the end of the tie-bar and it will already be there!

The Control PCB. Planning the position & mounting it.

We mention this first as each motor is fitted with a non-removeable pre-terminated connection lead so you will need to decide where to place the Cobalt-SS control board most conveniently for connection.

(Please note: As you will need to set up the throw distance as well as the addresses of your Cobalt-SS motors, you MAY find it easier to use set up your motors prior to fixing the Control Board under the layout). This is made easy to do by the "Plug and Play" nature of all connections.

Each DCCconcepts Cobalt-SS motor will be connected to a control board. Each control board will handle 2 motor addresses and each output can also handle TWO motors for a complete crossover from one output.

Your Cobalt-SS Control Boards will need to be mounted quite close to the motors that they control. Cobalt-SS motor lead length is 150mm and we include extension leads in each pack to give you a choice of position.

Every pack also includes 1 or more combined reverse-direction and Y connector leads to make complex interconnection easier. As one output is able to operate crossovers & loops this also makes it very economical.

Optional Accessories also include: (See the full list later in the manual)

(1) A Cobalt-SS "Crossover ADD-ON" pack that includes TWO additional Cobalt-SS motors and accessories including links, an extension lead and both Y-connection and Reverse connection adapters.

(2) A wide selection of Y-connectors, reverse adapters and extension leads plus, for the solderer... additional cable. Our Accessory packs will allow almost any possible configuration to remain plug and play.

Should you mount the Control PCB on top OR underneath? It is up to you. You can choose to install the Control Board above or below the baseboard. Wherever you choose to place the Control Board, please plan carefully and think about the following issues:

* If above the baseboard, it should be in a position that is easily accessed for connecting switches or LEDs, adjustment or set-up of the address.

It should also be protected from moisture while adding scenery and be in a safe position that will not allow metal fragments (from stripping wire etc) to fall onto the PCB surface and create accidental damage.

* If mounted below the baseboard, it should be close enough to each motor so that the plug is not awkward to insert or the lead pulled too tight (ie: when you install the motor and drill the small hole for the motor lead, please also allow for baseboard thickness plus a little slack in the lead). As the Cobalt-SS lead is 150mm long this generally means positioning the appropriate control board connection within 100mm of the hole.

* To fix the Control board in place, please use the screws provided and don't over-tighten them. If you prefer you can also use good quality foam mounting tape, but please use only 3M or a similar high quality brand foam tape as low cost discount-store tapes sometimes have slightly acidic glue and can potentially damage the copper tracks of the control board.

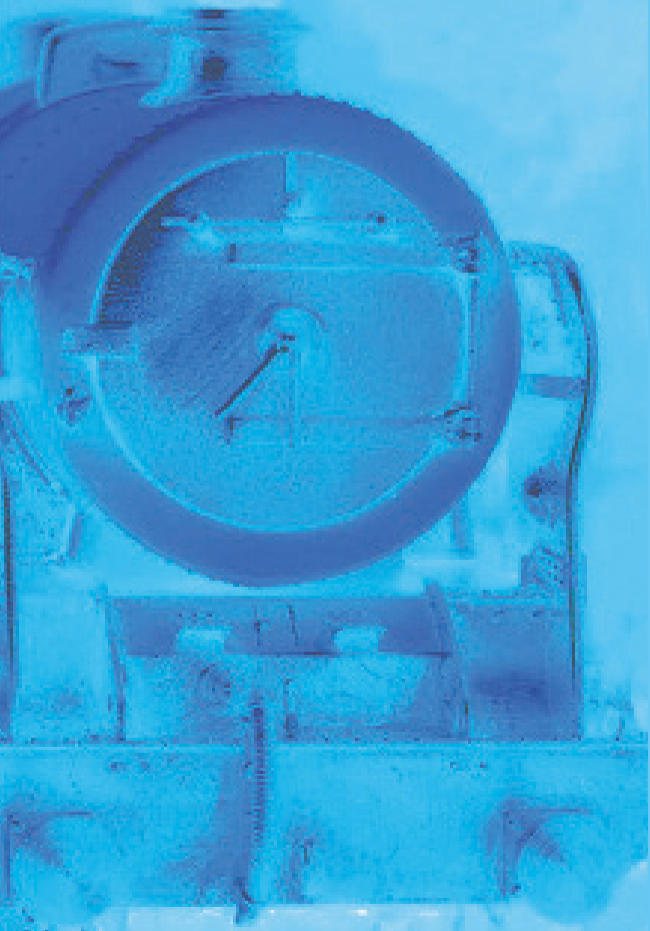

DCCconcepts Thinking outside the square

sales@dccconcepts.com www.dccconcepts.com

The complete range of Cobalt & Alpha products can be found on our website at

www.dccconcepts.com

Cobalt-SS

Installing, Connecting and Adjusting your Cobalt-SS Motors

A clear, visual indication helps, so here's another diagram with Cobalt-SS plus all of the wires & accessories connected. We have also added additional information where a more detailed explanation will be helpful.

Please note: We have used variants of Green, Red and Blue/Black to represent the added wires. Your wire choice is up to you!

When you wire, please read the manual then also read the print on the PCB as you insert the wires. With all the information also printed onto the PCB at every connection point, you should find it easy to get it all right first time!

We've shown only 1 set of connections: A Cobalt-SS Control Board can control 2 separate DCC addresses & several motors!

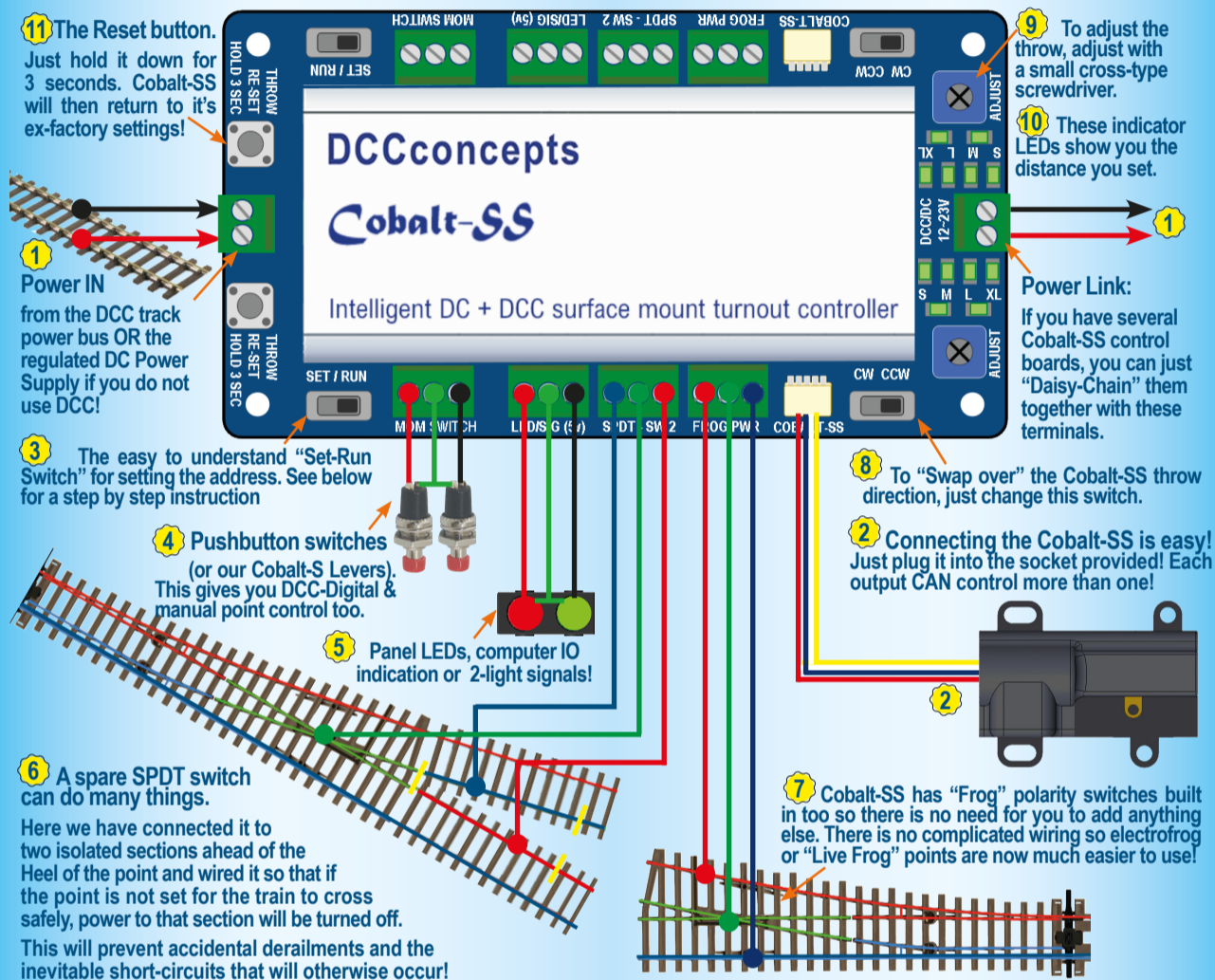

Cobalt-SS

Teaching your Cobalt-SS Motor it's new address and adjusting the throw distance

Setting the DCC Address of your Cobalt-SS Motor:



There are NO Complex DCC-digital commands or CVs to remember. Please use these instructions, not the accessory decoder instructions that are supplied with your DCC system.

SET → **RUN**

Please note that if you have a screen-based system such as the Roco Z21 or ESU ECoS you will need to create a track diagram or set up an on-screen turnout before you can set an Address.

- Connect your Cobalt-SS to the DCC track power bus or your dedicated DCC Accessory Power Bus.
- Decide which number you wish Cobalt-SS to use and then move the Set-Run switch to the "Set" position.
- Follow your DCC system instructions for changing a point or turnout using the number that you chose. (We repeat this procedure twice just to be sure)
- Return the Set-Run switch to the "Run" position.
- Repeat 3 and Cobalt-SS will respond to that address.

Adjusting the throw distance of a Cobalt-SS Motor:



All you will need to do is watch this set of six LEDs marked S - M - L - XL to clearly indicate the set position. As you GENTLY adjust the position of this with a fine "+" type screwdriver!

We chose the S - M - L - XL as it is a common designation on many things - indicating increase or change in size. You'll find that they correspond approximately to Z, N, OO/HO and O scale.

- Install your Cobalt-SS and test your installation leaving the settings at the factory default position.
- If the blade does not move fully either way, adjust the installation to improve centering then re-test it.
- If the blade moves across well before the motor stops, reduce the throw by turning the adjuster anti-clockwise.
- If the blade does not move fully or has weak pressure, increase the throw by turning the adjuster clockwise.
- To go back to a default throw, hold the "Re-Set" down.



Created by DCCconcepts

MADE IN CHINA

Cobalt-SS

Cobalt-SS: Basic wiring and features

Cobalt-SS Does not mind whether you power it with DCC or DC and is equally usable on layouts with either system.

Wiring is soldering-free. ALL connections are either very simple "Plug and Play" connections or Screw Terminals.

Each Cobalt-SS Control board has TWO control outputs & each output can control more than 1 Cobalt-SS motor.

Operation can be via two momentary switches or by DCC-Digital control and setting the address is easy to do.

Basic connection needs only 1, 2 and 3 to be used. These and all other Cobalt-SS connections are explained below.

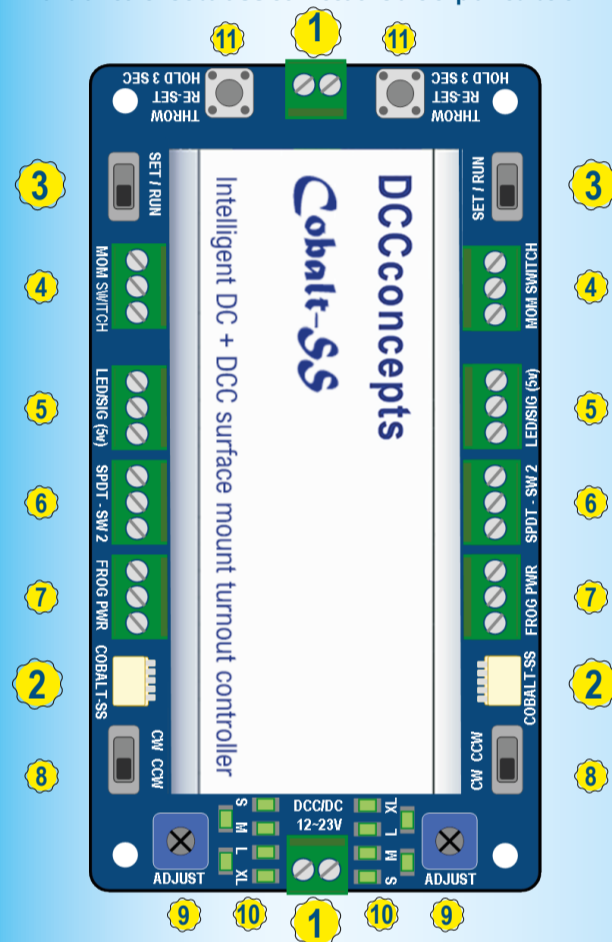

- Power Connection: Cobalt-SS works well with both DC and DCC power input. Voltage range is 12-23v.
- Cobalt-SS is connected with a simple plug & socket.
- DCC-Addressing is via a simple switch. Choose an address, move it to "Set", act as if already changing the turnout at that address and then return to "Run" mode.
- Momentary switch connection (Left/Com/Right).
- Panel LEDs or Computer I.O. or Colour Light Signals.
- Independent additional S.P.D.T. changeover switch.
- Turnout FROG power switching (Left/Com/Right).
- Cobalt-SS "Direction Swap" switch for reversing the direction of the turnout throw.
- Adjustment of Cobalt-SS "Point throw" distance for various scales or pointwork types.
- Indicator LEDs to guide your adjustment of the "Point throw distance. ("Small-Medium-Large-Extra Large")
- The Reset Buttons re-centre Cobalt-SS. It returns throw settings to factory Default. Hold for 3 seconds.

For more information visit our Website www.DCCconcepts.com
DCCconcepts Ltd (UK and Australia)
UK: Ph +44 (0) 1729 821 080
AU: Ph +61 (0) 8 9437 2470

COBALT-SS TWIN PACK



Created by
DCCconcepts

MADE
in
CHINA

The complete range of Cobalt & Alpha
products can be found on our website at

www.dccconcepts.com



Cobalt-SS

Loops, Crossovers & Special Wiring

Cobalt-SS is very economical for controlling crossovers, loops and similar arrangements, as a Cobalt-SS Control board can control two or more motors on each output.

And... as well as a "Change direction switch" on the Control board, (marked CW ~ CCW on the Control Board) we have included some useful 3-way adapter leads with every pack.

There is 1 in the 2 pack, 2 in the 6 pack and 4 in the 12 pack)

Our plug-and-play leads allow easy distance extension, an extension for a motor with swapped direction and simple "Wye" or Y-connection of two motors to any Control PCB output.

DCP-CBXO: 2x Cobalt-SS Motors, Plus 1x 50mm Y connection lead, 1x 50mm "Swap direction" lead and 2x medium extension leads for simple plug & play connection of loops or crossovers.

DCP-CBULL: A pack of 3x 1 metre long universal extension leads with a 3-way adapter to extend, Wye and reverse connect.

DCP-CBUML: A pack of 3x 600mm medium universal extension leads with 3-way adapter to extend, Wye & reverse connect.

DCP-CBYSL: A pack of 3x short (50mm) Y (Wye) connector leads for easy parallel connection of two Cobalt-SS motors.

DCP-CBRSL: A pack of 3x short (50mm) "Swap direction" leads for simple plug & play parallel connection for Cobalt-SS motors with one normal, one working in the reverse direction.

DCP-CBSSL: A pack of 3x 1 metre simple extension leads for easy plug and play extension of Cobalt-SS motor leads.

DCP-CBSML: A pack of 3x 600mm simple extension leads for easy plug and play extension of Cobalt-SS motor leads.

DCP-CB4WC: 6 Metres of Cobalt-SS 4-wire colour-coded ribbon cable for extending the leads on Cobalt-SS motors. Complete with heat-shrink. (Requires you to cut wires, so it is only for those modellers who do not mind soldering).

DCP-CBLLP: This pack contains a wide variety of parts to allow you to drive your pointwork with Cobalt-SS mounted at a distance. Pack includes Brass & Teflon tube, Phosphor bronze wire, some cranks and a selection of screws and linkages.

Cobalt-SS

Preparing pointwork for best performance

We have used PECO Electrofrog Pointwork for our example as many Cobalt-SS users use them on their layout.

Using other brands? No problem. ANY brand of live frog point can be wired like this, giving superior power pickup and slow speed reliability every time in any scale!

PREPARE THE TIE-BAR

Cobalt-SS needs a small hole at the end of the tie-bar but with Peco you may not have to drill! Just use some fine cutters OR a sharp scalpel blade to remove just the small vertical pin.

As the pin is hollow, this will leave a small hole ready for you to use with your choice of Cobalt-SS Linkages.

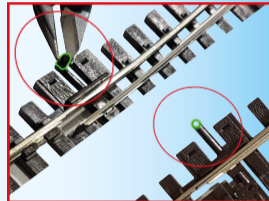

CUT the FROG LINKS and BOND the Stock-rails to the Closure rails.

This is NOT an issue related to Cobalt-SS... but it will greatly improve the overall performance and reliability of your layout and is "Best Practice".

The frog links to be cut are shown in yellow. They should be cut with sharp track cutters or similar. It will make it easier if you first lift the link slightly with a small screwdriver or similar.

The places to add the bonds are shown in RED. Use a short length of fine solid wire as a conductive bond between the places shown. If you use our S179 Solder and No-Clean SFNC flux it's a quick, easy soldering job.

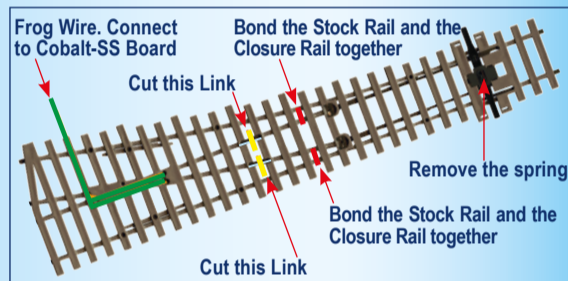

Connect more than one DCCconcepts Cobalt-SS motors to any Control Board output

All our examples use live or "Electrofrog" pointwork. For best and most reliable layout performance we recommend you follow the instructions on our website. Search for "Wiring Pointwork & Special track conditions for DC or DCC". Read Page 2.

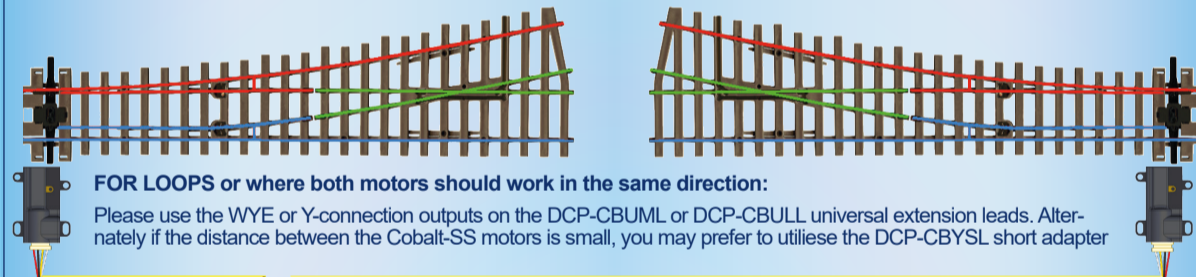

FOR LOOPS or where both motors should work in the same direction:

Please use the WYE or Y-connection outputs on the DCP-CBUML or DCP-CBULL universal extension leads. Alternatively if the distance between the Cobalt-SS motors is small, you may prefer to utilise the DCP-CBYSL short adapter

Do you need to make THREE Cobalt-SS Motors work together?

With Cobalt-SS that's easy. Just use two adapter boards together to achieve the motor throw directions needed. Each motor output on a Cobalt-SS Control Board can easily cope with three motors.

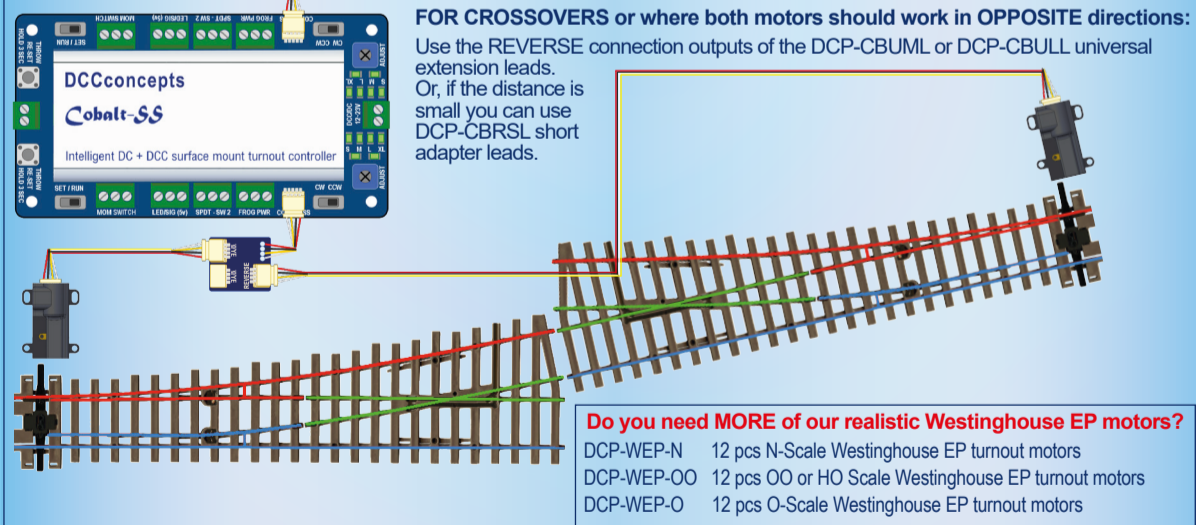

FOR CROSSOVERS or where both motors should work in OPPOSITE directions:

Use the REVERSE connection outputs of the DCP-CBUML or DCP-CBULL universal extension leads. Or, if the distance is small you can use DCP-CBRSL short adapter leads.

Do you need MORE of our realistic Westinghouse EP motors?

- DCP-WEP-N 12 pcs N-Scale Westinghouse EP turnout motors
- DCP-WEP-OO 12 pcs OO or HO Scale Westinghouse EP turnout motors
- DCP-WEP-O 12 pcs O-Scale Westinghouse EP turnout motors

Use Cobalt and Alpha products for turnout or layout control and nothing is impossible any more!



Cobalt-SS

Preparing the Tiebar & installing Links

We showed a little of this procedure in previous pages but we thought a bit more detail might make it clearer for you.

To install a Cobalt-SS link between motor and point, you will need a small hole at the end of the tiebar (about 0.3mm or 1/64th inch). Most modellers will have the 0.3mm drill needed for this, but if you use Peco pointwork, you won't have to drill!



We used our DCCconcepts DCT-XTC super-sharp track cutters but you could also use a sharp scalpel blade. Make a neat, tidy cut, parallel to the tie-bar.

Once the small vertical pin is taken off the tie-bar, the point will look better AND a perfectly formed hole will be revealed, ready for a Cobalt-SS linkage to be installed, as the image below shows!

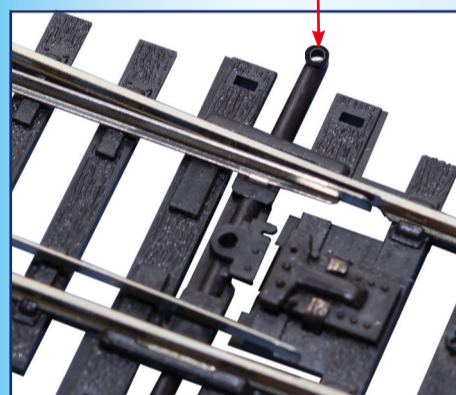

Now we have the pointwork ready to go, it is time to select the link you will use from the varieties that we supply, insert it into the Cobalt-SS point motor, then in turn, connect the link to the tiebar.

The primary difference between the links is the relative height between the two ends of the link.

The link you choose depends on the scale of your model - Z, N, O/HO or O etc, AND the thickness of your trackbed!

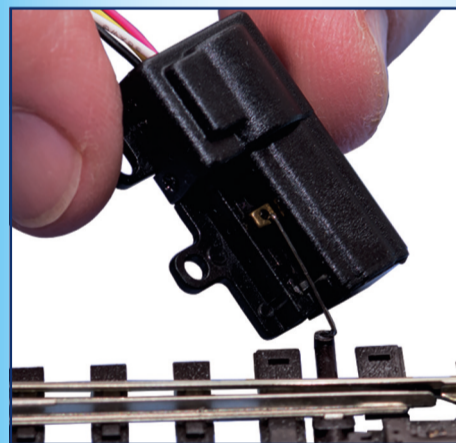

First, insert the smaller U-shaped end of the link into the hole in the phosphor bronze throw-bar of the Cobalt-SS motor.

Once that is done, insert the other end of the link through the hole in the point tiebar.

(Continued top of next page)

Cobalt-SS

Preparing pointwork for best performance

Once the link has been inserted and you rest the Cobalt-SS on the baseboard, the link should be close to parallel ~ horizontal.

If it is not, please consider adding a small, firm pad under the motor before fixing it down.

It just needs to be flat & firm, so card, wood or similar, cut a little larger than the motor and glued to the baseboard, are all OK.

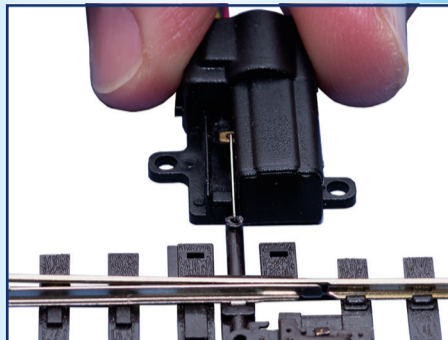

Photographs above and below show a Cobalt-SS motor with a link in place and ready to fix in place. Note that the motor is lined up with the tiebar & that the link is also reasonably parallel to the board.

- (1) Move the Cobalt-SS motor back forth until the far blade touches the adjacent rail.
- (2) Pre-drill a small pilot hole that in the center of the long fixing loop at each side of the motor
- (3) Insert one of the black screws into each slot, and tighten until it just touches the plastic of the Cobalt-SS case.
- (4) Using firm but gentle finger pressure on the "Wire-end" of your Cobalt-SS motor to make quite sure that the point blade is held firmly against its adjacent stock rail, then tighten each screw a just little more to fix it in place.
- (5) Insert one of the black screws into each slot, and tighten until it just touches the plastic of the Cobalt-SS case. (do not over-tighten)
- (6) Now pre-drill a small pilot hole that in the center of the round fixing lugs at each side of the motor and insert two more black screws. As with the first 2 screws, do not over-tighten.

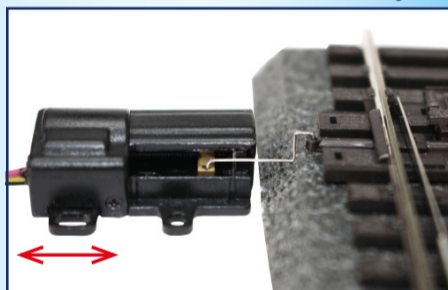

With the installation done, connect your Cobalt-SS motor to the control board and, after addressing or connecting momentary or push button switches, you can test your installation.

- (1) If its OK and the throw is just right. Re-check the screws are firm and move on to the next motor.
- (2) If the throw seems too far or completes before Cobalt-SS motor power turns off, reduce throw by using the blue adjuster screw (1) in the diagram. Lit LEDs should move from M towards S.
- (3) If the throw seems too small or incomplete, then increase the throw by using the blue adjuster screw (1) in the diagram. The lit LEDs should move from M towards XL.
- (4) If the throw still seems uneven or incomplete, then remove the screws from the round fixing lugs and slightly loosen the two screws in the longer loops. Re-centralise the motor then repeat steps 2 and 3 until operation is perfect.

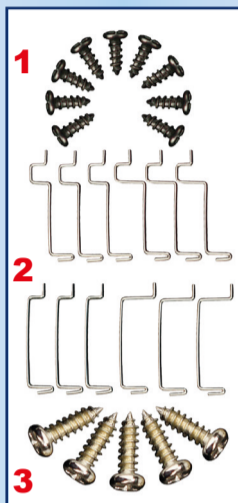

The items in the image above are some of the smaller items contained in the very comprehensive Cobalt-SS fitting kit. Every packet includes more linkages than motors and we even include a spare screw of each type

(1) These are blackened self-tapping screws to fix the your Cobalt-SS motors in place on the layout.

(2) These are the four different types of cranks supplied in every pack. We supply more than you will need so that you will have spares for later use.

(3) The silver screws are for fixing the Cobalt-SS control board to the layout.

Mounting Cobalt-SS further away from your pointwork Easy: Simply cut one of the links in half and solder the ends to a little brass wire.

We have also made you a "Distant Mounting Pack"

It is complete with springy but easy to solder PB wire, some tubes, some cranks and a wide set of linkages so you can do many clever things with Cobalt-SS!

For the more adventurous modeller we're nearly ready to launch our working point rodding kit too, so you can then take it to the extreme!

We are modellers first and foremost & we love to see our products in action, so if you have the time, we'd really appreciate it if you could send a picture to show us how you are using Cobalt-SS!

Use Cobalt and Alpha products for turnout or layout control and nothing is impossible any more!